

# AZURE

lighting solutions



Stretchable extension



## Latenlux Mega Series Retractable Downlight



AZURELIGHTINGSOLUTIONS.COM  
+61 9188 7712

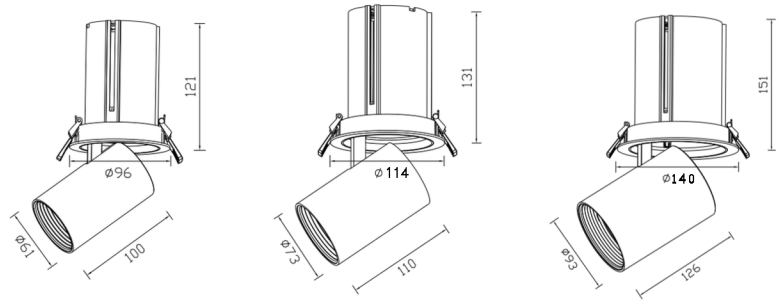

## Product Specifications

Power Consumption:	Up to 15W	Up to 25W	Up to 35W
Total luminous flux:	Up to 1564lm	Up to 2610lm	Up to 3850lm
Dimensions (DxH):	Ø61x100mm	Ø73x110mm	Ø93x126mm
Cutout (D):	Ø85mm	Ø105mm	Ø125mm
Beam Angle:	15°, 24°, 36°, 60°	15°, 24°, 36°, 60°	15°, 24°, 36°, 60°
Adjustability:	Adjustable	Adjustable	Adjustable

## General Specifications

Fixture Material:	Aluminium
Trim Finish:	Black, White, Custom
Mounting:	Recessed
Diffuser (Optional):	Honeycomb Louver, Frosted Glass
LED Type:	CREE COB
Binning:	3 Step MacAdam
Correlated Colour Temperature	2700K, 3000K, 3500K, 4000K, 5000K
Colour Rendering Index:	>90
R9 Value:	>50
Light Distribution:	Symmetric
Optical Cut-off Angle:	35°
Ambient Operating Temperature:	-25° to 50°
Driver Input Voltage:	220-240VAC 50-60Hz
Control Gear:	TCI
Control Options:	Fixed Output, DALI, Push Dim, 0-10V, Casambi
Protection Class:	Class II
Lumen Maintenance:	L80 B10 60,000 Hours
IP Rating:	IP20
Warranty:	7 Years

Lumen values are based on CRI90 at CCT 4000K

All product specifications and data are subject to change without notice

## Specification Code

Latenlux.60	. A .	15 .	20 .	927.	N .	15 .	B
	<b>A=Adjustable</b>	<b>15=15W</b>	<b>20=IP20</b>	<b>927=2700K</b> 930=3000K 935=3500K 940=4000K 950=5000K 960=6000K 965=6500K	<b>N=NON DIM</b> D=DALI P=PUSH DIM T=TRIAC DIM O=0-10V C=CASAMBI	<b>15=15°</b> 24=24° 36=36° 60=60°	<b>B=BLACK</b> W=WHITE
Latenlux.70	. A .	25 .	20 .	927.	N .	15 .	B
	<b>A=Adjustable</b>	<b>25=25W</b>	<b>20=IP20</b>	<b>927=2700K</b> 930=3000K 935=3500K 940=4000K 950=5000K 960=6000K 965=6500K	<b>N=NON DIM</b> D=DALI P=PUSH DIM T=TRIAC DIM O=0-10V C=CASAMBI	<b>15=15°</b> 24=24° 36=36° 60=60°	<b>B=BLACK</b> W=WHITE
Latenlux.90	. A .	35 .	20 .	927.	N .	15 .	B
	<b>A=Adjustable</b>	<b>35=35W</b>	<b>20=IP20</b>	<b>927=2700K</b> 930=3000K 935=3500K 940=4000K 950=5000K 960=6000K 965=6500K	<b>N=NON DIM</b> D=DALI P=PUSH DIM T=TRIAC DIM O=0-10V C=CASAMBI	<b>15=15°</b> 24=24° 36=36° 60=60°	<b>B=BLACK</b> W=WHITE

## Accessories

+ 1

1=Honeycomb Louver  
2= Frosted Glass



Honeycomb  
Louver



Frosted  
Glass

## Colour Rendering Index

The Color Rendering Index (CRI) serves as a metric to gauge how accurately a light source portrays the colors of various objects in a given space. Originally comprised of 8 sample colors, the CRI has expanded to 15 samples to provide a more comprehensive evaluation. Notably, within these samples, R9 to R15 focus on assessing special colors with high chroma. Specifically, R9 evaluates the rendering of red tones, while R15 is dedicated to evaluating the portrayal of skin tones. This extension of color samples, coupled with attention to high-chroma colors, enhances the precision in evaluating a light source's ability to faithfully reproduce a diverse range of colors.

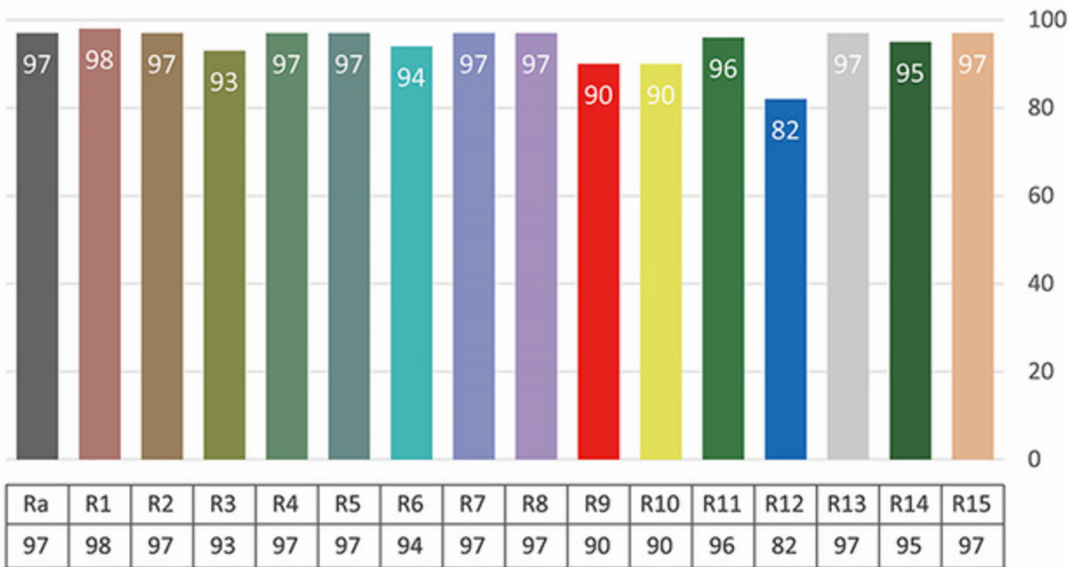
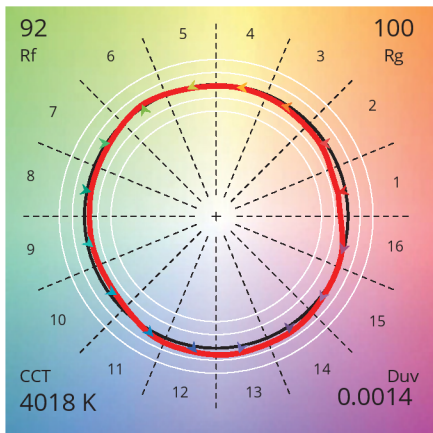

Fig 1 - Colour Rendering Index 4000K, CRI >95

**TM30** Rf 92  
Rg 100



## IES TM-30

TM-30 is the Illuminating Engineering Society (IES) Method for Evaluating Light Source Color Rendition, is a standard developed by the IES to assess the color rendering properties of light sources. It provides a comprehensive set of metrics and values that go beyond the traditional color rendering index (CRI), offering a more detailed and accurate understanding of how well a light source renders colors.

Fig 2 -Colour Vector Graphic 4000K, CRI >90